



The Matchbox® 360-12



MORE AIR= BETTER QUALITY, FASTER

Patented air flow technology means 3x more air than traditional impingement.

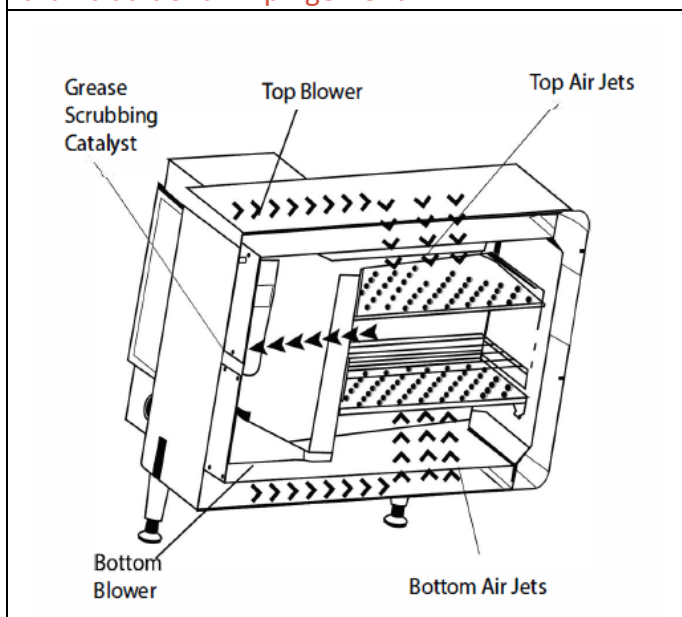

STANDARD FEATURES

- ✓ Independently controlled top and bottom blowers with speeds up to 567 CFM (ft³/min)
- ✓ Reduced energy consumption (documentation available)
- ✓ Less impact on HVAC costs (documentation available)
- ✓ Precision Impingement™ utilizes hot air for a fast, high- quality cook without microwaves
- ✓ FlexTemp technology changes cavity temperature by up to +/- 25°F between cook cycles
- ✓ Load and unload food automatically
- ✓ Warranty - 1 year parts and labor

OPERATION

- ✓ Touch screen display with security passcode and countdown timer
- ✓ Holds up to 600 multistage recipes
- ✓ USB port - upload and download recipes, view cook logs, diagnostic mode

PERFORMANCE

- ✓ Fits up to a 12" pizza, or (3) 7" pizzas
- ✓ Grill, roast, bake, steam, broil, and air fry
- ✓ Use any oven-safe pans. Specialty pans available

CONSTRUCTION

- ✓ 304 stainless steel interior
- ✓ 430 stainless steel exterior
- ✓ Easy to clean design (filters and jet plates are dishwasher safe)
- ✓ Decorative coverings or powder coat available

VENTILATION

- ✓ No hood system required*
 - ✓ UL listed for operation without a Type 1 hood in accordance with EPA 202 test
 - ✓ UL and cUL listed for multiple stacking configurations
 - ✓ Performs 2.5X better than the required UL"
- *Type 2 hood necessary if HVAC cannot accommodate thermal load

PROUDLY MADE IN THE USA



Short Form Specification: Provide Ovention Matchbox® 360-12 Precision Impingement™ Oven with patented triple-layer impingement jet plates made of 304 stainless steel to maximize heat transfer, (2) half-moon cook surfaces capable of fitting 12" pizza, electric, certified UL and cUL ventless, countertop, internal catalytic filtration, intuitive digital display interface, two 1/3HP variable-speed motors, built-in self-diagnostics, 430 stainless steel front, top, sides and back, cool touch exterior, 304 stainless steel interior, USB menu upload capability, Autoload and Auto unload with built in queueing ability to virtually eliminate lag time between cooks, FlexTemp almost instantly changes +/- 50F between cooks, 4" adjustable height legs, 6400 heater watts, 25/28 amps, 208-240v/60hz/1-ph, NEMA 6-30P, Made in USA.



OventionOvens.com | 855.298.6836 | connect@ventionovens.com

Search Ovention to download our app.



The Matchbox® 360-12

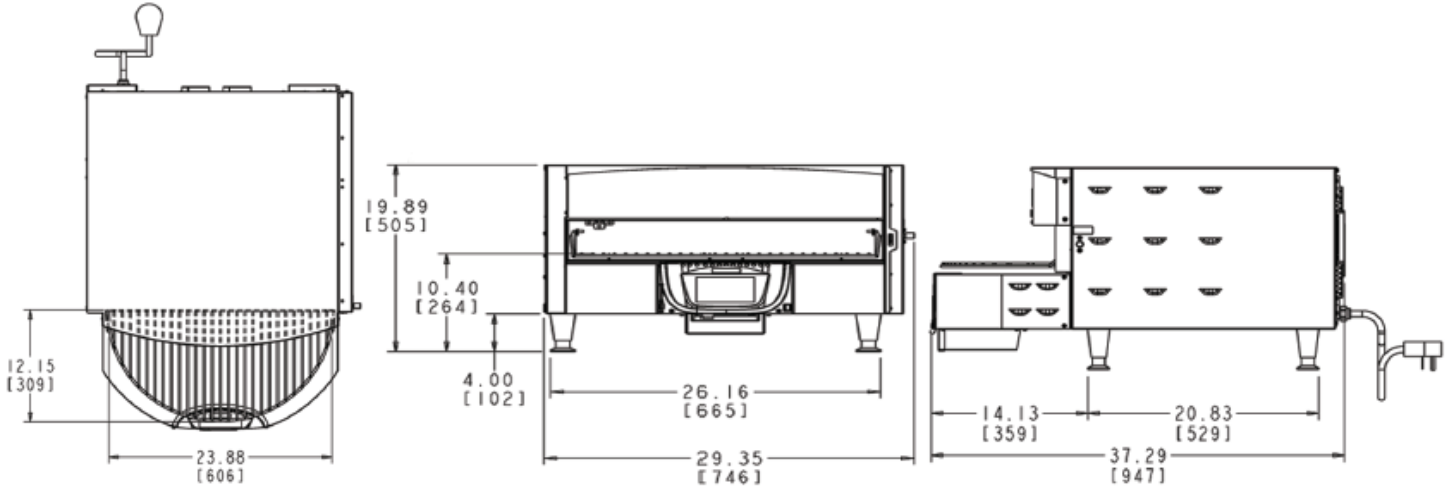

Inches [millimeters]

ELECTRICAL SPECIFICATIONS

Height	15.9"	405mm
With Legs	19.9"	505 mm
Width	29.4"	746 mm
Depth	37.3	947 mm
Weight	211 lbs.	84 kg
Minimum Clearance	0" Top	0 mm Top
	2" Back	51 mm Back
	0" Side	0 mm Side

Model Number	M360-12	
Temperature	82-525 °F	28-274° C
Voltage	208-240 VAC	 NEMA 6-30
Heater Watts	6.4 kW	
Amperage	25-28	
Phase	1 ph	
Frequency	60 Hz	
Cord Length	72"	1829 mm

CAVITY DIMENSIONS**

Height	3.5"	89 mm
Width	23.9"	607 mm
Depth	12.3" [12" pie / custom pan]	311 mm [30 cm pie / custom pan]

SHIPPING INFORMATION

Cube (LxWxH)	32x40x49"	81x102x125 mm
Shipping Weight	275 lbs.	124.7 kg
Freight Class	175	
Point of Origin	Sturgeon Bay, Wisconsin, USA	

** Measurements: actual [useable] dimensions

**Ovention, Inc. reserves the right to make technical improvements



OventionOvens.com | 855.298.6836 | connect@oventionovens.com

Search Ovention to download our app.

