



Project _____

Item No. _____

Quantity _____

The Matchbox® M1718

EXTERIOR CONSTRUCTION

- 430 Stainless Steel exterior
- Cool-to-touch exterior, all surfaces below 50°C
- Category leading whisper quiet operation at 67dB
- 4-inch adjustable legs (included)
- Dual front-facing color 5-inch touchscreen displays

INTERIOR CONSTRUCTION

- 20-inch fully insulated 304 stainless steel cook chamber
- Patented top and bottom stainless steel triple-layer impingement jet plates
- Easy to clean design with dishwasher safe jet plates

STANDARD FEATURES

- Integral recirculating catalytic converter for UL listed ventless operation
- Patented dual auto-load & unload capability
- Patented sealed baking chamber for menu flexibility allows for 2 to 8 times the airflow rate of a typical conveyor oven, reduced cook times, energy use and HVAC loading for 40-50% lower operating costs
- FlexTemp dynamic temperature management allows ±50°F between cook cycles
- Intuitive front-facing touch controls can store 1000+ recipes Industry leading online menu & recipe software allows for easy menu creation and management via USB drive
- Self-diagnostics for monitoring oven components and performance
- Smart Voltage Sensor Technology* manages variances in 208 & 240V operations
- Automatic Power Save mode when not cooking for maximum energy conservation
- High visibility countdown timers
- Independently controlled top and bottom Precision Impingement® air with variable-speed recirculation
- External easy-access air filtration
- Stackable up to 2-high (stacking kit required)†
- 6-ft cord and plug
- 1 year Parts and Labor Warranty

STANDARD OPTIONS & ACCESSORIES

- Stacking kit for double stack assembly (OVNTN-STK-8)
- Dozens of other accessory options available

CERTIFICATIONS



This product conforms to the ventilation recommendations set forth by NFPA96 using EPA202 test method.

* Smart Voltage Sensor Technology does not compensate for lack of or over voltage situations. It is the responsibility of the owner to supply voltage to the unit according to the product specifications.

† Ventless certification is for all food items except for foods classified as “fatty raw proteins”. Such foods include bone-in, skin-on chicken, raw hamburger meat, raw bacon, raw sausage, steaks, etc. If cooking these types of foods, consult local HVAC codes and authorities to ensure compliance with ventilation requirements. Ultimate ventless allowance is dependent upon AHJ approval, as some jurisdictions may not recognize the UL certification or application. If you have questions regarding ventless certifications or local codes, please email



THE MATCHBOX® M1718

MORE AIR= BETTER QUALITY, FASTER
Patented air flow technology means 3x more air than traditional impingement.

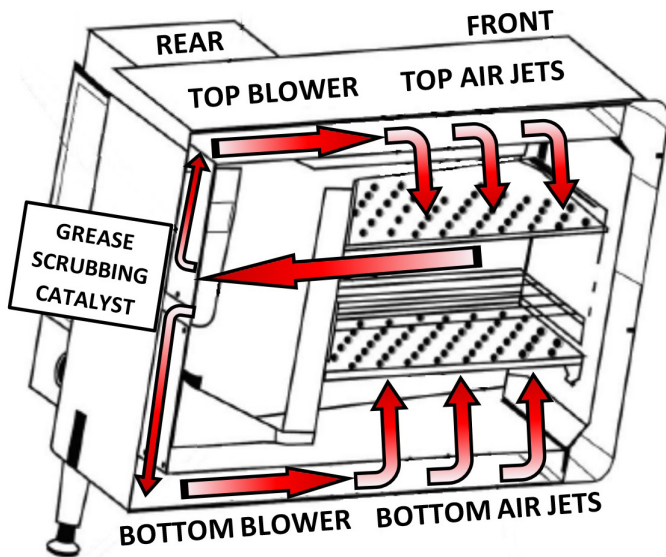

VENTLESS OPERATION DETAILS †

- UL (KNLZ) listed for ventless operation
- EPA 202 test: Qty (328) 12” pepperoni pizzas, 525°F, 8 hrs
-Results: 0.49 mg/m³
-Ventless Requirement: < 5.00 mg/m³
- Internal catalytic filtration to limit smoke, grease, and odor emissions

See ventionovens.com/patents for a complete list of applicable U.S. and international patents



OventionOvens.com | 855.298.6836 | connect@ventionovens.com
Search “Ovention” to download our app.



DOC?? - Revision B/6/2021

Specifications are subject to change without notice and are not intended for installation purposes.

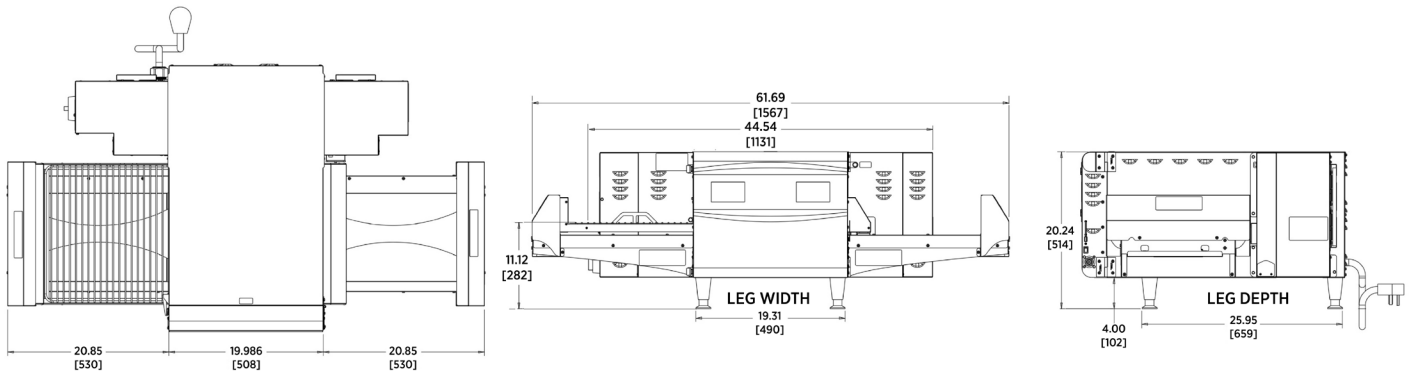

Measurement Units: Inches [Millimeters]

DIMENSIONS			ELECTRICAL SPECIFICATIONS			
HEIGHT	20.25"	514 mm	US	208-240V/60Hz/1-ph, 44/49 amps, UL, NEMA 6-50P and cord - standard	Max Input: 12.3kW Heater Input: 11kW	 NEMA 6-50
WIDTH	61.69"	1567 mm				
DEPTH	34.47"	876 mm				
WEIGHT	228 lb.	103 kg	US/CANADA	208V/60Hz/1-ph, 40 amps, cULus NEMA 6-50P and cord	Max Input: 11.3kW Heater Input: 10kW	 IEC 60309 3P+N+PE
CAVITY DIMENSIONS			INTERNATIONAL	230-400V WYE/50Hz/3ph, 23 amps, CE, IEC 60309 3P+N+PE and cord	Max Input: 12.3kW Heater Input: 11kW	
HEIGHT	3.5"	89 mm				
WIDTH	20"	508 mm	SHORT FORM SPECIFICATIONS			
DEPTH	18"	458 mm	Provide Ovention Matchbox® M1718 Precision Impingement® Conveyor Oven, Ventless, Rapid Cook, countertop, dual 17" X 18" cooking platforms with auto load/unload, 20" sealed bake chamber, triple-nozzle impingement plates, (2) touch screen displays, built-in self-diagnostics, USB menu upload, smart voltage sensor technology, FlexTemp dynamic temperature management, automatic power save mode, cool to touch 430 ss exterior, 304 ss interior, 4" adjustable legs, Made in USA, cULus, CE, UL EPH Classified, ANSI/NSF 4.			
MINIMUM CLEARANCE						
LEFT/RIGHT/BACK	1/1/1"*	25/25/25 mm*				
SHIPPING INFORMATION						
CUBE (LxWxH)	68 x 41 x 31"	1727 x 1041 x 787mm				
SHIPPING WT.	312 lb.	142 kg				
FREIGHT CLASS	175					
POINT OF ORIGIN	Sturgeon Bay, WI, USA					

*If units are stacked, 6" (152 mm) back and side clearance needed

Due to periodic changes in designs, methods, procedures, policies and regulations, the specifications contained in this sheet are subject to change without notice. While Ovention® exercises good faith efforts to provide information that is accurate, we are not responsible for errors or omissions in information provided or conclusions reached as a result of using the specifications. By using the information provided, the user assumes all risks in connection with such use.